

instructional manual

rattler beverage dispenser

dispenser model No. 950C

Please refer to the Taprite website (www.taprite.com) for information relating to Taprite installation and Service Manuals, Instruction Sheets, Technical Bulletins, Service Bulletins, etc.

Rev: 1/24/2020
PN: 805-0039GB



NOTICE:

The information contained in this document is subject to change without notice.

TAPRITE MAKES NO WARRANTY OF ANY KIND WITH REGARD TO THIS MATERIAL, INCLUDING, BUT NOT LIMITED TO, THE IMPLIED WARRANTIES OF MERCHANTABILITY AND FITNESS FOR A PARTICULAR PURPOSE. TAPRITE shall not be liable for errors contained herein or for incidental consequential damages in connection with the finishings, performance, or use of this material.

This document contains proprietary information which is protected by copyright. All rights reserved.

© Copyright 2019 by Taprite, all rights reserved.

THIS DOCUMENT CONTAINS IMPORTANT INFORMATION

This manual must be read and understood before the installation and operation of this dispenser.

Taprite

3248 Northwestern Drive • San Antonio, TX 78238
210.662.8200 • Fax: 210.646.6009 • www.taprite.com
Toll-Free 877.404.2488

TABLE OF CONTENTS

SUBJECT	PAGE NUMBER
◦ Installation	3
◦ Setting Ratio	5
◦ Flow Control Cover Installation	7
◦ Butterfly Plate and Button Removal/Reassembly	7
◦ Removing and Replacing Stem O-Ring	7
◦ Cleaning and Maintenance	8-9
◦ Reattaching the Bar Gun Assembly	10
◦ Troubleshooting	11
◦ Line Configuration	12
◦ Juice and Energy Butterfly Plate Configurations	13
◦ 8 and 10 Butterfly Plate Configurations	14
◦ 12 and 14 Butterfly Plate Configurations	15-16
◦ Button Plate Configurations	17
◦ Accessories	18-19
◦ Handle Assembly	20-21
◦ Manifold Assembly	22-23
◦ Flow Control Module Assembly	24-25
◦ Mechanical Module Assembly	26-27
◦ Mounting Plate Screw Placement	28
◦ Patent & Patent Pending Numbers	28
◦ Part Number Format	29

INSTALLATION

Thank you for purchasing a Taprite 950C bar dispenser. All required mounting hardware, holster assembly, and ¼” stainless-steel input fittings (with o-rings) are included with each bar dispenser. The stainless-steel input fittings are installed on the product side of the bar dispenser manifold (Fig. 1). These fittings are secured in place using the red retainer clips.



Fig. 1

IMPORTANT

THIS EQUIPMENT MUST BE CONNECTED TO A POTABLE WATER SUPPLY AND INSTALLED WITH ADEQUATE BACK FLOW PREVENTION TO COMPLY WITH FEDERAL, STATE, AND LOCAL CODES.

Attach the base plate (smooth side out) with provided #8 screws. Please see Page 26 for optimal screw placement.

IMPORTANT

THE BASEPLATE PROVIDES STABILITY FOR THE BAR DISPENSER AND SHOULD BE ATTACHED TO A FLAT SURFACE. FAILURE TO INSTALL THE BAR DISPENSER AND BASEPLATE ON A FLAT SURFACE WILL VOID THE WARRANTY AND MAY CAUSE THE VALVE MODULE ASSEMBLY TO LEAK.

To install the fitting, press the barb side of the fitting into the tubing and past the last fittings barb. Secure the tubing to the fitting with an Oetiker clamp positioned upright.

INSTALLER TIP:

Do not install the tubing flush with the flange, this will cause the tubing to interfere with the retainer clip. Failure to install Oetikers as shown in Figure 1 will place stress on the valve module assembly and cause a leak.

- A. If a staggered setup is necessary, input fittings are available in two additional lengths: “medium” (1.5” length), and “long” (2.7” length) (Fig. 2).



Fig. 2

- B. Follow the labeling on the assembly to ensure proper product connection.
- C. Lock inlet line fittings into the valve module assembly before turning on syrup or water. To lock the fitting, lightly press down on the red clip. Lightly pull up on the clip to allow fitting removal. (Caution: Forcibly removing the red clip from the valve body may damage the clip).



Fig. 3

- D. The bar dispenser assembly comes from the factory pre-attached to the valve module assembly. Before proceeding to the next step verify that the red retainer clips are in the locked position (down) (Fig. 3).
- E. Rotate the yellow shut-off stem 90 degrees to “Off” position to check for inlet connection leaks (Fig. 4).

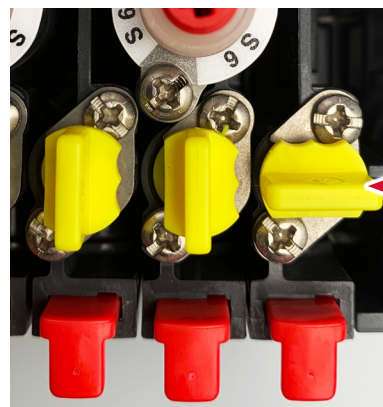

Fig. 4

- F. Slide Flow Control Module/Mechanical Module (FCM/MM) onto base plate and verify that the two bosses on the plate are lined up. Secure the manifold to the base plate with the two thumb screws.
- G. To install the holster use the screws provided. Install the holster and drain assembly

in close proximity to the bar gun location. Holster mounting plate must be placed so that the release tab is accessible. Plumb the holster using 1/2" standard drain hose and follow local plumbing codes. Refer to the cleaning and maintenance section for proper removal and cleaning of holster.



IMPORTANT

NEVER PLACE THE HOLSTER DIRECTLY OVER THE ICE BIN. HOLSTER INSERT CAN BE REMOVED AND USED WITH OTHER BAR DISPENSER HOLSTERS.

INSTALLER TIP:

Place your bar dispenser as close as possible to the product cooling source to minimize the dispensing of warm product and reduce foaming of the finished drinks.

SETTING RATIO

The Bar Dispenser has been thoroughly tested and sanitized prior to shipment. The installer will be required to set the ratio of the bar dispenser.

INSTALLER TIP:

Installer must cool or chill the product before setting the ratio of the system. Ratio will be different in cold product and warm product.

IMPORTANT

BEFORE SETTING RATIO, PURGE PRODUCT AND WATER THROUGH BAR DISPENSER TO ENSURE PROPER PRODUCT TEMPERATURE.

- A. Rotate the yellow shut-off stem to the "on" position (Fig. 4).
- B. To adjust water flow rate, press plain water button or carbonated water button on bar dispenser and capture water in a graduated cylinder or ratio cup, while timing the dispense. Divide the volume of water dispensed by the time. This will equal the flow rate in oz/s
- C. To adjust the flow, turn the red adjustment screw (Fig 6). To regulate a ceramic FCM, turn clockwise to increase flow and counterclockwise to decrease flow. If the flow control assembly contains a green adjustment screw it is a MM. To regulate flow, turn counterclockwise to increase flow and clockwise to decrease flow (opposite of ceramic flow control) (Fig. 7)

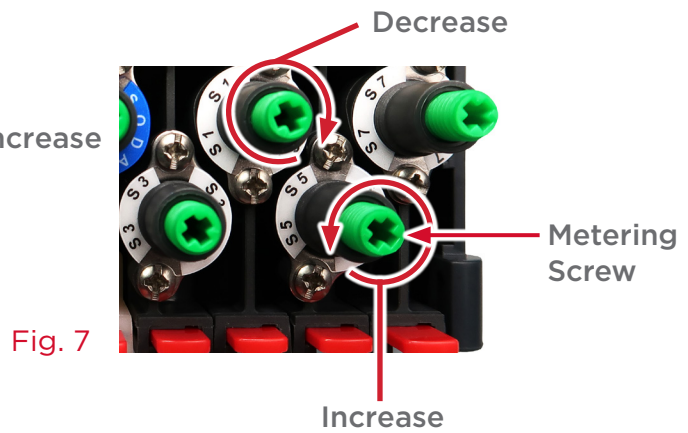
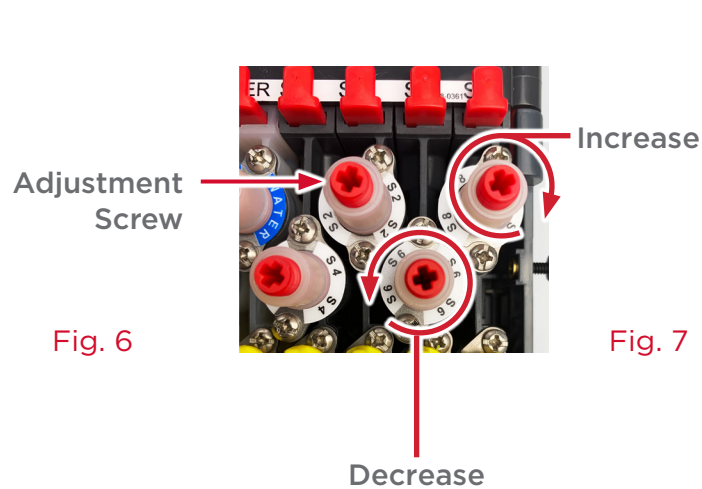

NOTE:

The Bar Dispenser is designed to flow 1.50 oz/sec. finished drink.
This is the proper setting for 5:1 ratio.

D. To achieve the proper water flow rate, adjust the red screw within the flow control module. For the mechanical application adjust the green metering screw (Fig. 7).

INSTALLER TIP:

Depending on the pressure of the incoming plain water, the maximum flow for the dispenser may not be achievable. There are two solutions to this problem.

- 1) Adjust the Brix/Ratio to account for the slower flow rate.
- 2) Add a water booster to the system.

E. To Ratio/Brix the final product, remove dispensing nozzle on bar gun assembly.

F. Replace the dispensing nozzle with the Taprite syrup separator nozzle. Line up the separator nozzle on the diffuser and turn to lock the nozzle in place. Ensure there is a tight seal against the diffuser.

G. Use a ratio cup to measure the syrup to water ratio. Adjust the flow controls to achieve the target ratio.

INSTALLER TIP:

The Taprite Bar Dispenser is equipped with a secondary water ratio screw that is located on the bottom of the bar dispenser handle near the nozzle (Fig. 8). This may be used to slow the flow of water to maintain proper ratio for products with ratios 1:1 or 2:1 or any high-viscosity product. The screw comes from the factory in the open position and should be used only in the conditions noted. This screw only controls water flow to the products associated with the bottom right hand butterfly plate.

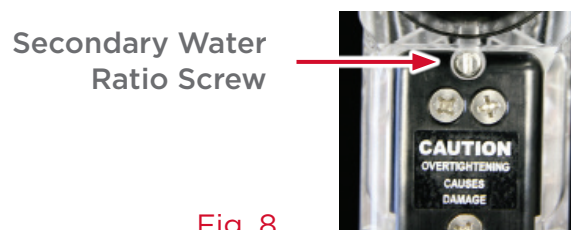

FLOW CONTROL COVER INSTALLATION

- A. Loosen thumb screws keeping them evenly spaced for the cover to slide between.
- B. To install flow control cover, align the slots on the cover with the thumb screws on the valve/ bracket assembly.
- C. Align slot with thumb screws and tighten on each side of cover.

Note: Thumb screws do not have to be removed completely

BUTTERFLY PLATE AND BUTTON REMOVAL/REASSEMBLY

Taprite Bar Dispenser can be configured for numerous combinations of carbonated and non-carbonated products. All combinations can be made without shutting down the product and soda/water system. The button plate can be removed while the bar dispenser is pressurized by simply removing the two screws on the bar dispenser head.

- A. To change butterfly plate, remove button plate.
- B. Remove both Phillips screws and butterfly retainers.
- C. Lift butterfly plates out of handle.
- D. Align the pivot balls of the replacement plates located on the bottom of the butterfly plate, with the depressions in the bar gun handle.

INSTALLER TIP:

The pivot balls on the butterfly plate must align with the depressions in the bar dispenser handle for the bar dispenser to work properly.

- E. Secure butterfly plates in position using the Phillips screws and butterfly retainers (**BE CAREFUL NOT TO OVERTIGHTEN**).
- F. Replace button plate and reattach with Phillips screws.

REMOVE AND REPLACE STEM O-RING

- A. Rotate yellow Shut-off stem 90 degrees on module assembly to turn off water and products. Press the buttons on the bar dispense to release the pressure.
- B. Place bar gun handle on flat surface, nozzle facing up.
- C. Remove the button and the butterfly plates. The valve stems are located under the plates.

INSTALLER TIP:

Carefully remove bottom plate, by lifting straight up. Small springs are located below the plate and may fall out.

- D. Remove Phillips screws and the bottom plate
- E. Using an appropriate tool, push valve stem down and out of the handle.
- F. Working from the bottom plate side, use the spear end of the o-ring tool (P.N. 316-0003) to remove the o-ring (P.N. 208- 5003)
- G. Place new o-rings on the plain end of the tool, lubricate with a small amount of food grade lubricant.
- H. Install o-ring in the hole and make sure it is firmly seated.

INSTALLER TIP:

It is required to use a food grade lubricant.

- I. Replace valve stem, install springs in the valve handle.

INSTALLER TIP:

ALL VALVE SPRINGS MUST BE SEATED IN THE RECESS OF THE BOTTOM PLATE TO PROPERLY ALIGN WITH THE HANDLE.

- J. Slowly press bottom plate into handle until it is completely seated.
- K. Hold the bottom plate and replace the retaining screws.

INSTALLER TIP:

DO NOT OVER TIGHTEN THE RETAINING SCREWS.

- L. Replace butterfly plates.
- M. Replace button plate.

CLEANING AND MAINTENANCE

The Bar Dispenser is shipped from the factory cleaned and sanitized in accordance with NSF guidelines. The bar dispenser must also be cleaned and sanitized after installation is complete. It is recommended that the operator provide continuous maintenance as required by the manual and/or state and local guidelines to ensure proper operation.

IMPORTANT

DO NOT CLEAN WITH OR ALLOW CONTACT WITH HARSH CHEMICALS CONTAINING ATBC (ACETYL TRIBUTYL CITRATE) OR OTHER ORGANIC SOLVENTS (CLEANER/DEGREASERS, PESTICIDES AND PESTICIDE FOGGERS). THIS WILL CAUSE PERMANENT DAMAGE TO PLASTIC COMPONENTS.

HANDLE IMPORTANT

DO NOT SUBMERGE THE HANDLE IN HOT WATER. THIS WILL CAUSE PERMANENT DAMAGE TO THE DISPENSER AND ITS COMPONENTS.

A. External Cleaning

Cleaners (ivory liquid, calgon, etc.) should be mixed with clean potable water at a temperature of 90 to 110 degrees F. The acceptable mixture ratio is one ounce of cleanser to two gallons of water. Any NSF approved equivalent cleaner may be used. Rinse with clean potable water.

IMPORTANT

ONLY USE INTERNAL CLEANING SOLUTIONS THAT ARE APPROVED FOR BEVERAGE DISPENSER APPLICATIONS, SUCH AS KAY-5®. (NO CAUSTIC CHEMICALS SUCH AS INDUSTRIAL KITCHEN CLEANING CHEMICALS SHOULD EVER BE USED)

B. Sanitizing

Sanitizing solutions must provide 50 to 100 parts per million (PPM) available chlorine. Any sanitizing solution may be used as long as it is prepared in accordance with the manufacturer's recommendations.

C. Daily Cleaning

1. **Dispenser Handle**

Remove nozzle from bar dispenser handle. Fill container about 6" with warm (never hot) water. Allow the dispenser handle and nozzle to soak in the water for 10 to 15 minutes. This will remove any syrup or soda residue from the nozzle and buttons. It should not be soaked overnight.

NOTE:

It is recommended that the nozzle be removed and cleaned daily.

2. All external parts can be cleaned by wiping with a cloth soaked with warm cleansing detergent. Inspect the hose to ensure all residue is removed.

D. Deep Cleaning of Bar Dispenser Whip

1. Rotate yellow Shut-off stem 90 degrees to turn off water/product (Fig. 9).
2. Turn the two (2) wing screws to release the FCM/MM from the base plate (Fig 10).
3. Slide FCM/MM module out of mounting plate.
4. Snap the red retainer clips to the open position (Fig 11).
5. Locate the two slotted red screw separators on the outside of the bar gun manifold and turn the screws clockwise. This will separate the bar gun dispenser from the FCM/MM module (Fig. 12).

NOTE:

Alternate turning red screw separator to evenly remove the bar gun manifold from the module. The Shut-off tool (P.N. 316-0005), or a screw driver, can be used to aid in removing the dispenser assembly but is not necessary.

Fig. 9

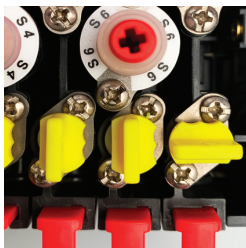

Fig. 10

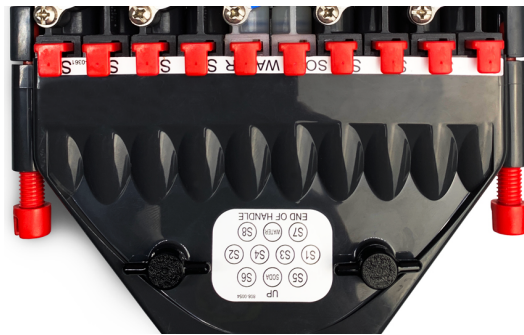
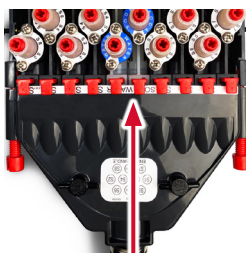
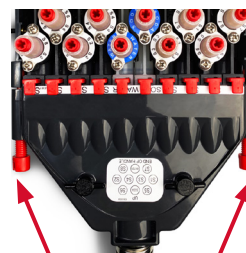

Fig. 11



Red Clips

Fig. 12



Screws

6. Fill a bar sink or a 5 gal. bucket with sanitizing solution that is mixed to mfg. recommendations (50 to 100 PPM). Allow the bar gun whip assembly to soak in the solution for 10 to 15 minutes. Using a cloth and brush, wash and clean the hose. Inspect the hose to ensure all residue is removed. It should not be soaked overnight.

7. Rinse with warm water and allow to dry.

E. Holster Cleaning

1. Daily Cleaning

For daily cleaning, press carbonated water button or water button on bar handle while sitting in the holster to flush product residue down drain. You may also pour warm water down the receptacle to clean holster.

2. Bi-weekly Cleaning

- a. To remove holster assembly, push tab located behind the nozzle receptacle. Slide holster assembly forward (toward you) (Fig. 13-14).
- b. Separate the bar gun receptacle from the drip tray (Fig. 15).
- c. Refer to sanitizing section in 3-B.

Fig. 13



Fig. 14



Fig. 15



NOTE:

Check the back of the drip tray drain connector to ensure there is no damage to the o-rings

(P.N. 208-5112-429) (Fig. 15)

REATTACHING THE BAR GUN WHIP ASSEMBLY

- A. Adjust the red screw separators on the outside of the bar gun assembly so the small smooth shank is exposed.
- B. Slide the bar gun manifold into the FCM/MM module.
- C. Snap red retainers into the locked position.
- D. Slide FCM/MM module and bar dispenser into locked position on mounting plate and secure with wing screws
- E. Rotate yellow Shut-off stem 90 degrees to the open position and check for leaks.
- F. Depress all buttons on bar dispenser head to remove any trapped air or sanitizing solution.
- G. Bar Dispenser is ready for operation.

TROUBLE SHOOTING

- A. Push water - no water dispensed
 - Check water supply
 - Check Shut-off (is it open)
 - Check ratio/brix adjustment
 - Check for proper butterfly plate
- B. Push syrup - no syrup dispensed
 - Check CO₂ pressure
 - Check for product
 - Check Shut-off
 - Check ratio/brix adjustment
 - Line plugged
- C. Push soda - no soda dispensed
 - Check carbonator
 - Check water supply
 - Check CO₂ pressure
 - Check Shut-off
 - Check ratio/brix adjustment
 - Check for proper butterfly plate
- D. Push product - dispensing incorrect product
 - Check for proper plumbing
 - Check for proper butterfly plate
- E. Weak product taste
 - Check syrup CO₂ supply
 - Check ratio/brix adjustment
 - Check for plugged line
 - Check Shut-off - open completely
 - Check syrup supply
- F. Strong product taste
 - Check ratio/brix adjustment
 - Check carbonator pressure
 - Check syrup CO₂
- G. Continuous dispense
 - Check butterfly plates - damaged or too tight
 - Check for debris in syrup or water passages
- H. Product leaking from bottom plate
 - Defective stem o-ring
 - Bottom plate screws are loose
 - Warped or damaged button plate

LINE CONFIGURATION

8 Button

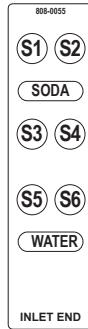
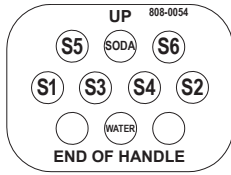

S7 S5 S1 S3 SODA WATER S4 S2 S6 S8

10 Button

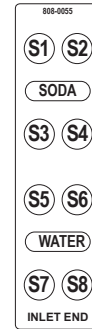
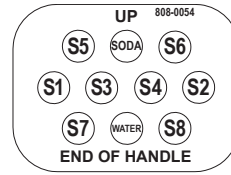

S7 S5 S1 S3 SODA WATER S4 S2 S6 S8

12 Button

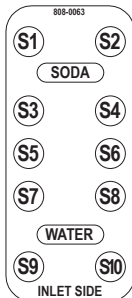
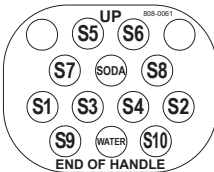

S11 S9 S7 S5 S1 S3 SODA WATER S4 S2 S6 S8 S10 S12

14 Button

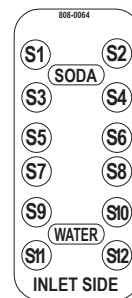
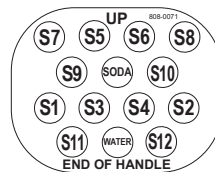

S11 S9 S7 S5 S1 S3 SODA WATER S4 S2 S6 S8 S10 S12

JUICE AND ENERGY BUTTERFLY PLATE CONFIGURATION

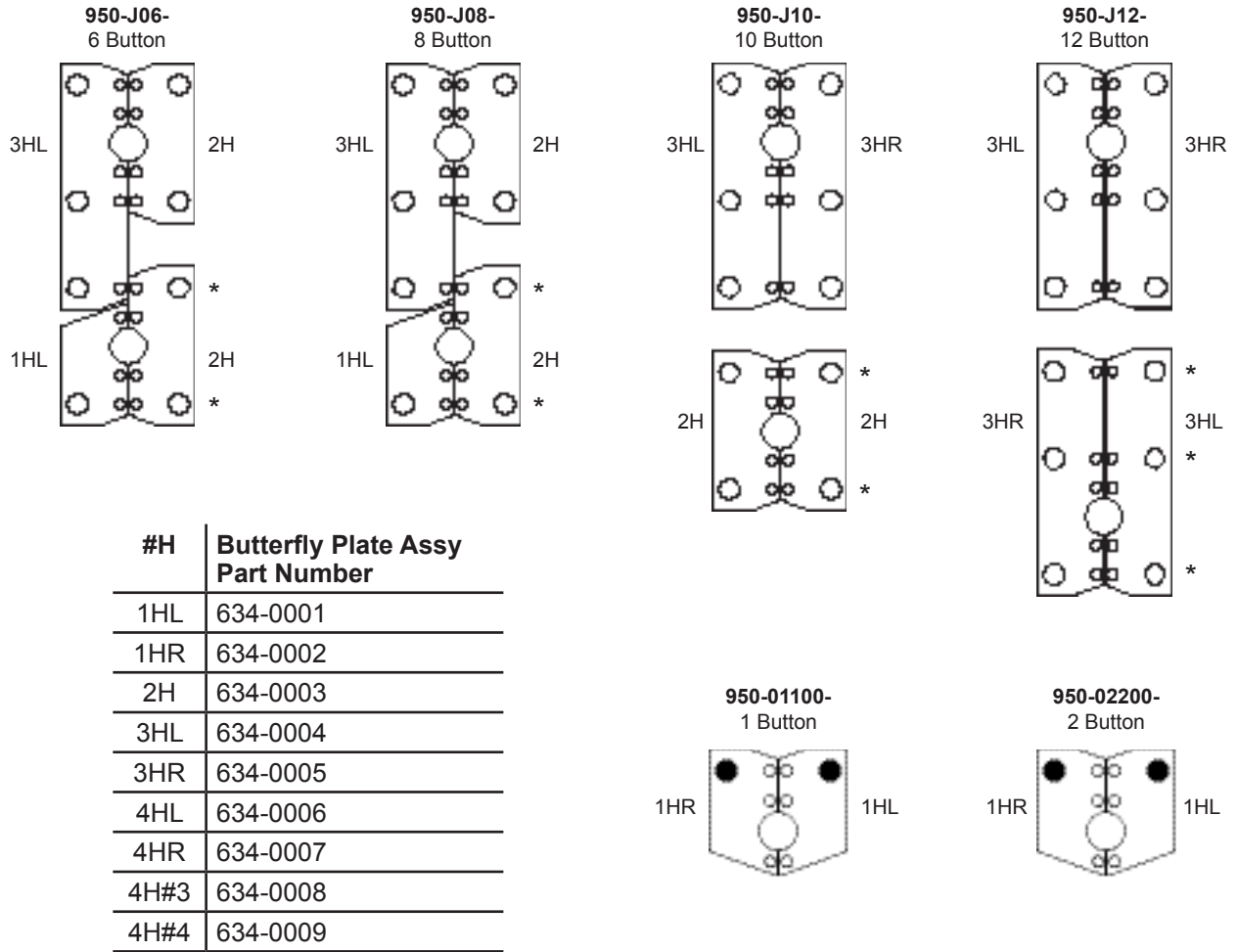

● = Carbonated Positions
 ○ = Non-Carbonated Positions

* = Secondary Water Metering Screw Affects These Positions
 ® = Requires Soda/Water Button Foot (P.N. 265-0039/265-0040)
 Extensions Into Bottom Of Button Where Symbol Appears.

8 AND 10 BUTTON BUTTERFLY PLATE CONFIGURATIONS

950-10800-
 8 Button Carbonated
 0 Button Non-Carbonated
 0 Pre-Mix

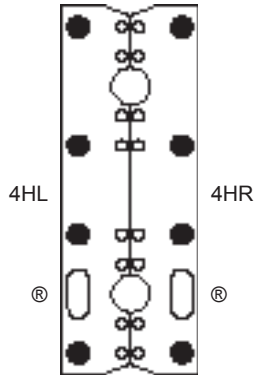

950-10710-
 7 Button Carbonated
 1 Button Non-Carbonated
 0 Pre-Mix

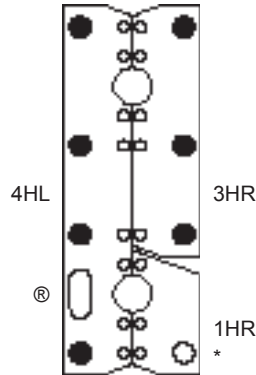

950-10620- & 950-08600-
 6 Button Carbonated
 2 Button Non-Carbonated
 0 Pre-Mix

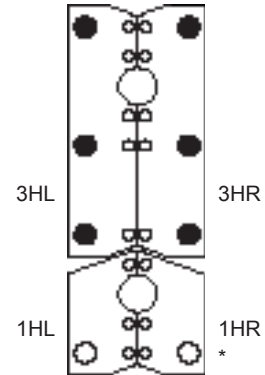

950-10530- & 950-08510-
 5 Button Carbonated
 3 Button Non-Carbonated
 0 Pre-Mix

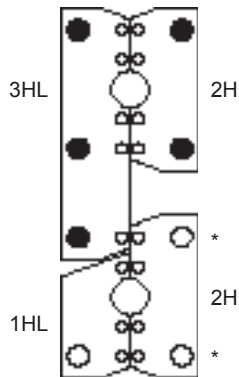

950-10440-
 4 Button Carbonated
 4 Button Non-Carbonated
 0 Pre-Mix

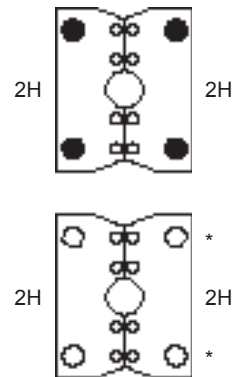

950-10350-
 3 Button Carbonated
 5 Button Non-Carbonated
 0 Pre-Mix

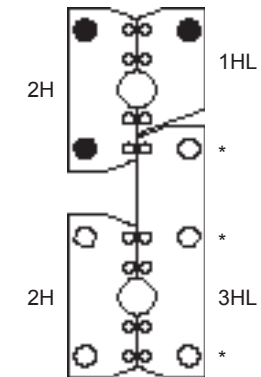

950-10260-
 2 Button Carbonated
 6 Button Non-Carbonated
 0 Pre-Mix

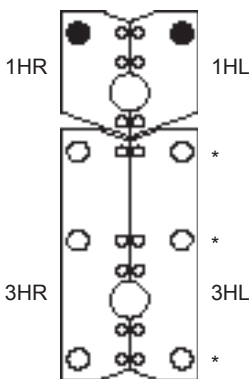

950-10170-
 1 Button Carbonated
 7 Button Non-Carbonated
 0 Pre-Mix

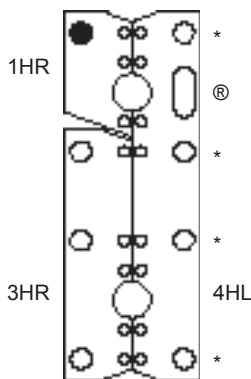

950-10080-
 0 Button Carbonated
 8 Button Non-Carbonated
 0 Pre-Mix

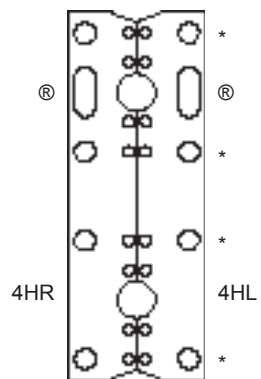

● = Carbonated Positions
 ○ = Non-Carbonated Positions
 #H = See Chart on Page 12 for Part Number

* = Secondary Water Metering Screw Affects These Positions
 ® = Requires Soda/Water Button Foot (P.N. 265-0039/265-0040)
 Extensions Into Bottom Of Button Where Symbol Appears.

12 AND 14 BUTTON BUTTERFLY PLATE CONFIGURATIONS

950-12820-
8 Button Carbonated
2 Button Non-Carbonated
0 Pre-Mix

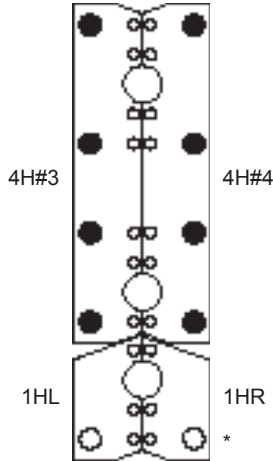

950-12730-
7 Button Carbonated
3 Button Non-Carbonated
0 Pre-Mix

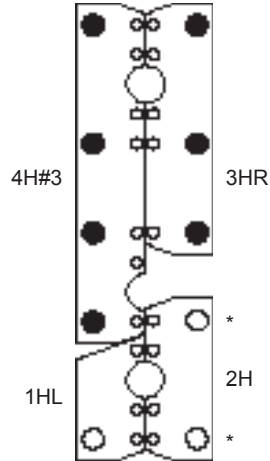

950-12640-
6 Button Carbonated
4 Button Non-Carbonated
0 Pre-Mix

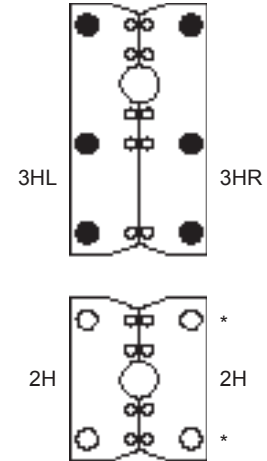

950-12550-
5 Button Carbonated
5 Button Non-Carbonated
0 Pre-Mix

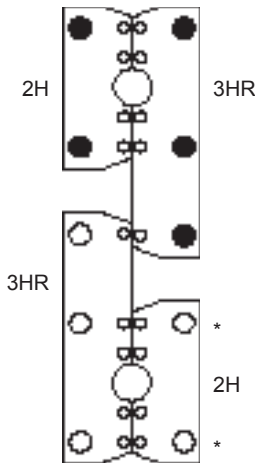

950-12460-
4 Button Carbonated
6 Button Non-Carbonated
0 Pre-Mix

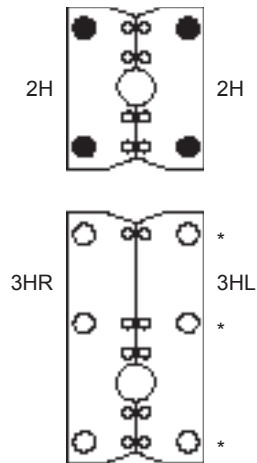

950-12370-
3 Button Carbonated
7 Button Non-Carbonated
0 Pre-Mix

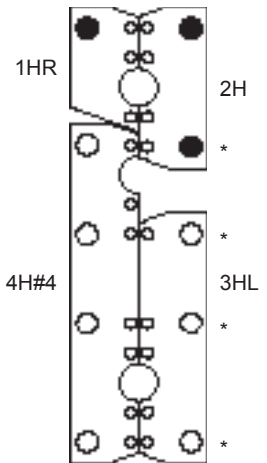

● = Carbonated Positions
○ = Non-Carbonated Positions
#H = See Chart on Page 12 for Part Number

* = Secondary Water Metering Screw Affects These Positions
Ⓜ = Requires Soda/Water Button Foot (P.N. 265-0039/265-0040)
Extensions Into Bottom Of Button Where Symbol Appears.

12 AND 14 BUTTON BUTTERFLY PLATE CONFIGURATIONS

950-12280-
2 Button Carbonated
8 Button Non-Carbonated
0 Pre-Mix

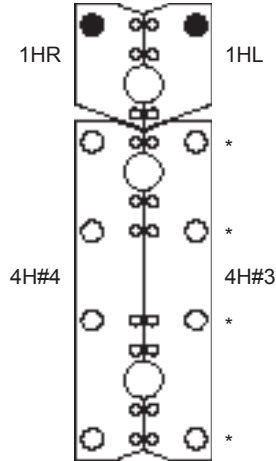

950-14840-
8 Button Carbonated
4 Button Non-Carbonated
0 Pre-Mix

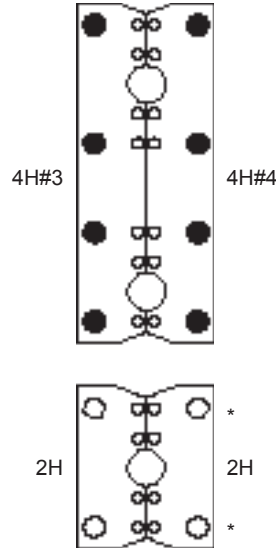

950-14750-
7 Button Carbonated
5 Button Non-Carbonated
0 Pre-Mix

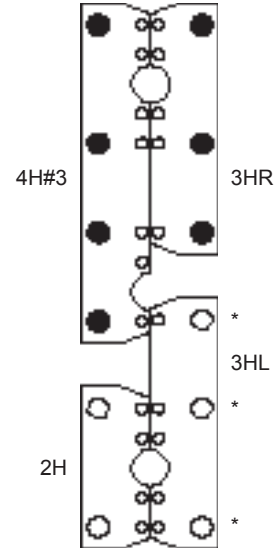

950-14660-
6 Button Carbonated
6 Button Non-Carbonated
0 Pre-Mix

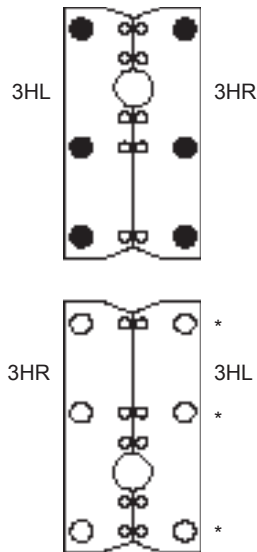

950-14570-
5 Button Carbonated
7 Button Non-Carbonated
0 Pre-Mix

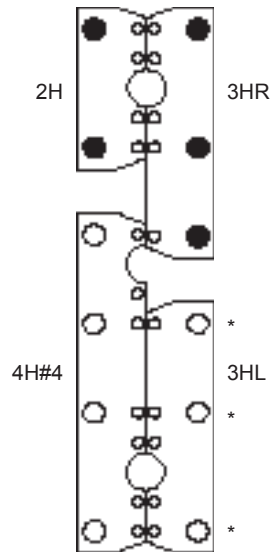

950-14480-
4 Button Carbonated
8 Button Non-Carbonated
0 Pre-Mix

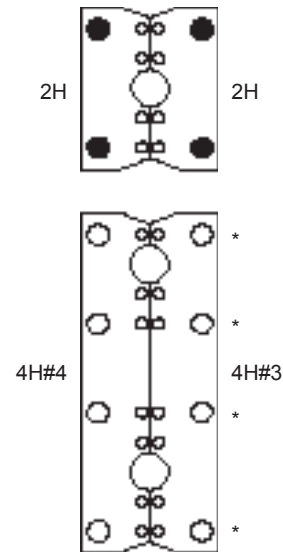

● = Carbonated Positions
○ = Non-Carbonated Positions
#H = See Chart on Page 12 for Part Number

* = Secondary Water Metering Screw Affects These Positions
Ⓢ = Requires Soda/Water Button Foot (P.N. 265-0039/265-0040)
Extensions Into Bottom Of Button Where Symbol Appears.

BUTTON PLATE CONFIGURATIONS

015



659-0015
8 BUTTON
6C/0NC

014



659-0014
10 BUTTON
5C/3NC, 6C/2NC, 8C/0NC

019



659-0019
12 BUTTON
6C/4NC, 7C/3NC

020



659-0020
14 BUTTON
6C/6NC, 8C/4NC

PLEASE CONTACT CUSTOMER SERVICE FOR OTHER PLATE CONFIGURATIONS

ACCESSORIES

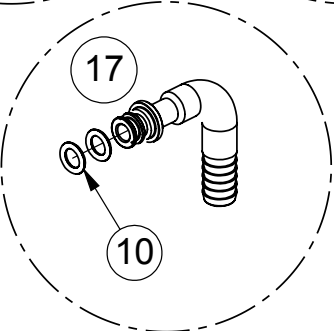
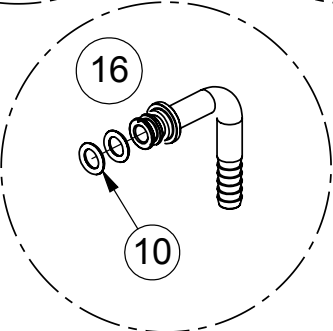
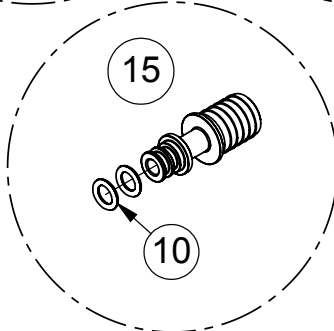
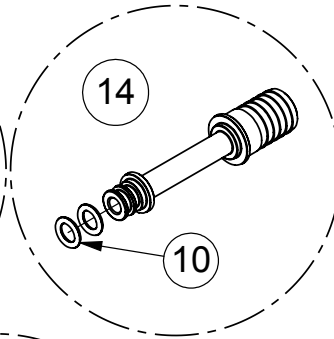
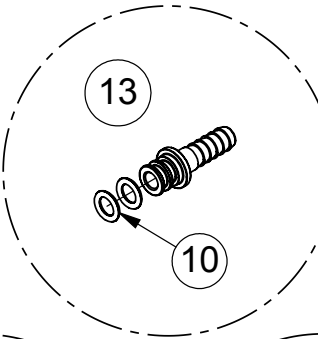
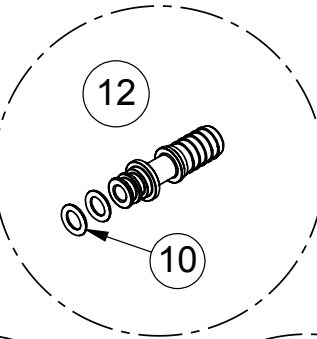
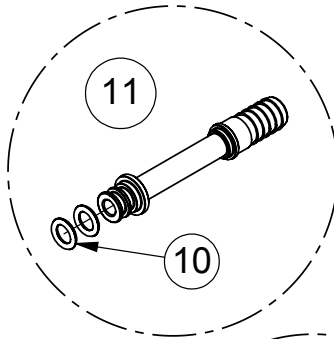
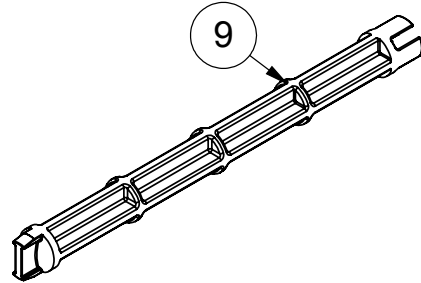
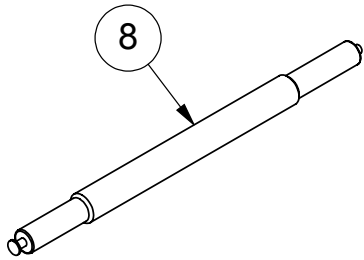
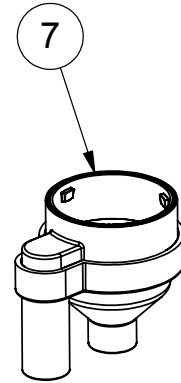
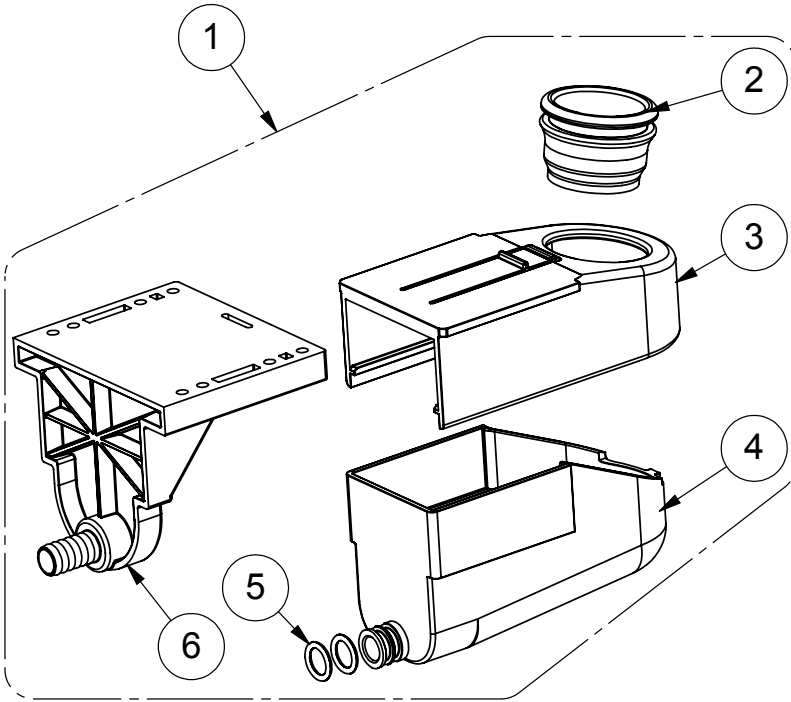

ACCESSORIES

ACCESSORIES PARTS LIST		
ITEM	SCHROEDER PN	DESCRIPTION
1	675-0017-SP	KIT, HOLSTER ASSY, W/SCREWS/BG, BLACK, 5/PK
2	315-0016	INSERT, HOLSTER, SHORT, BARGUN
3	265-0151	HOLSTER, BARGUN, BLACK
4	265-0152	DRIPTRAY, BARGUN, BLACK
5	208-5112-SP	KIT, O-RING, 2-112, EPDM, 100/PK
6	265-0153	BRACKET, MOUNTING, BARGUN, BLACK
7	316-0004-SP	SEPARATOR, BARGUN, 5/PK
8	316-0003-SP	TOOL, INSERT/EXTRACTOR, O-RING, 5/PK
9	316-0005-SP	TOOL, SHUTOFF, 5/PK
10	208-5010-SP	KIT, O-RING, 2-010, EPDM, 100/PK
11	625-0065-SP	KIT, FITTING ASSY, 3/8 BARB x 2.70"L, W/FLANGE, 25/PK
12	625-0066-SP	KIT, FITTING ASSY, 3/8 BARB x 1.50"L, W/FLANGE, 25/PK
13	625-0067-SP	KIT, FITTING ASSY, 1/4 BARB x 1.25"L, W/FLANGE, 25/PK
14	625-0068-SP	KIT, FITTING ASSY, 1/2 BARB x 2.70"L, W/FLANGE, 25/PK
15	625-0069-SP	KIT, FITTING ASSY, 1/2 BARB x 1.50"L, W/FLANGE, 25/PK
16	625-0070-SP	KIT, FITTING ASSY, 1/4 BARB, ELBOW, W/FLANGE, 25/PK
17	625-0071-SP	KIT, FITTING ASSY, 3/8 BARB, ELBOW, W/FLANGE, 25/PK
18	030-0017	DRAIN TUBE, BARGUN (NOT SHOWN)

HANDLE ASSEMBLY

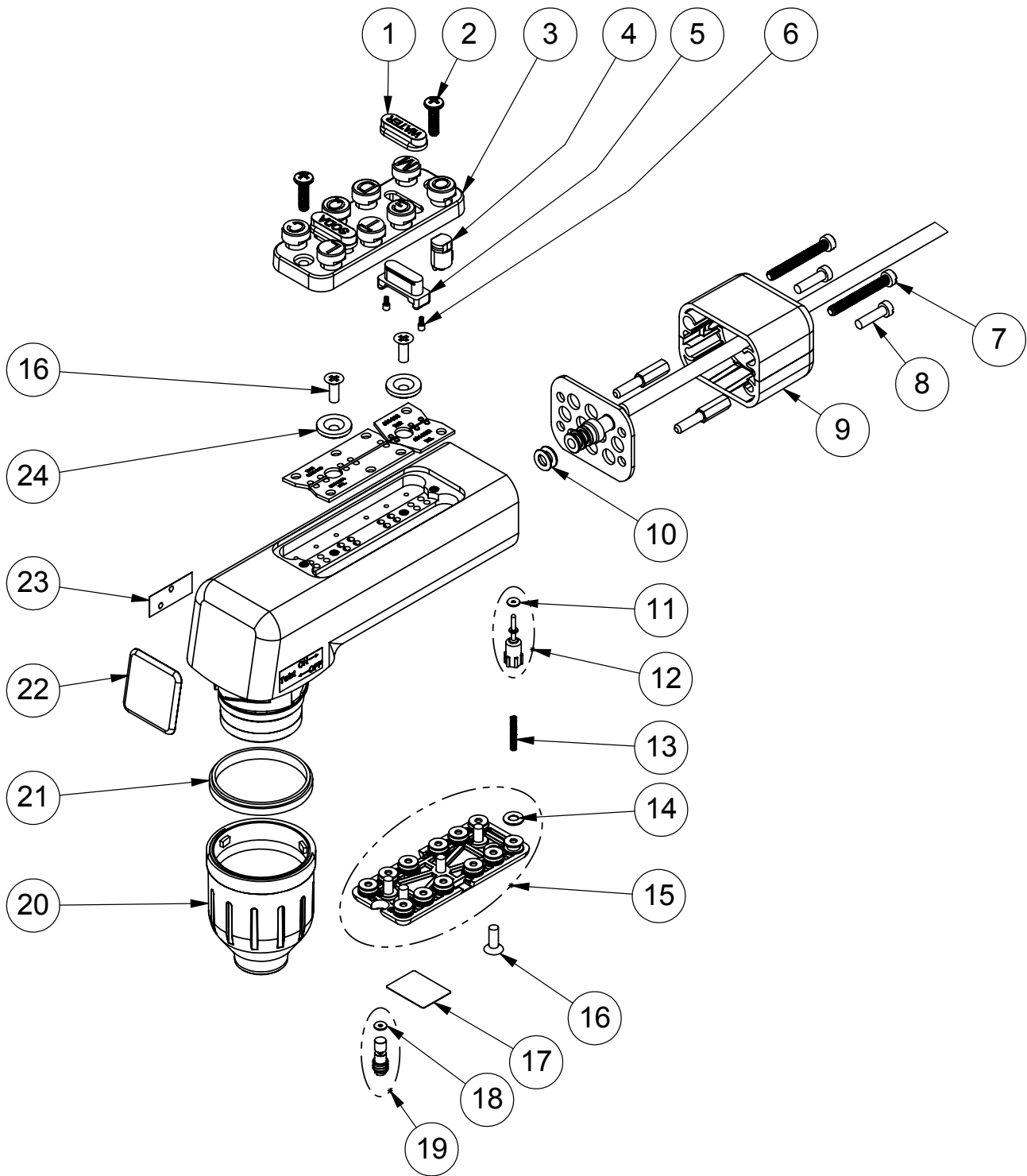

HANDLE ASSEMBLY

BARGUN HANDLE PARTS LIST		
ITEM	SCHROEDER PN	DESCRIPTION
1	265-0039-SP	KIT, BUTTON, WATER, OVAL, 50/PK
	265-0040-SP	KIT, BUTTON, SODA, OVAL, 50/PK
2	220-0012-SP	KIT, SCREW, 6-32 x .500, PH, PHD, SS, 50/PK
3	265-0229-SP	KIT, PLATE, BUTTON, 3B, BLACK, 5/PK
	265-0223-SP	KIT, PLATE, BUTTON, 5B, BLACK, 5/PK
	265-0205-SP	KIT, PLATE, BUTTON, 6B, JUICE, BLACK, 5/PK
	265-0196-SP	KIT, PLATE, BUTTON, 8B, BLACK, 5/PK
	265-0202-SP	KIT, PLATE, BUTTON, 8B, JUICE, BLACK, 5/PK
	265-0009-SP	KIT, PLATE, BUTTON, 10B, BLACK, 5/PK
	265-0089-SP	KIT, PLATE, BUTTON, 12B, BLACK, 5/PK
	265-0092-SP	KIT, PLATE, BUTTON, 14B, BLACK, 5-PK
4	265-0007-SP	KIT, ACTUATOR, SINGLE, 50/PK
	265-0083-SP	KIT, ACTUATOR, SINGLE, PREMIX, 50/PK
5	265-0004-SP	KIT, ACTUATOR, WATER/SODA, 50/PK
6	279-0014-SP	KIT, EXTENSION, ACTUATOR, WATER/SODA, 100/PK
7	220-0009-SP	KIT, SCREW, 6-32 x 1.125, SL, FHD, SS, (3B, 5B, 10B), 100/PK
	220-0015-SP	KIT, SCREW, 6-32 x 1.562, SL, FHD, SS, (12B, 14B), 100/PK
8	220-0010-SP	KIT, SCREW, 6-32 x .500, SL, FHD, SS 100/PK
9	631-0028-SP	KIT, HEEL ASSY, HANDLE, 6B, BLACK, 5/PK
	631-0010-SP	KIT, HEEL ASSY, HANDLE, 10B, BLACK, 5/PK
	631-0023-SP	KIT, HEEL ASSY, HANDLE, 12/14B, BLACK, 5/PK
10	208-5008-SP	KIT, O-RING, 2-008, EPDM, 100/PK
11	208-5003-SP	KIT, O-RING, 2-003, EPDM, 100/PK
12	625-0040-SP	KIT, STEM & O-RING ASSY, BARGUN, 25/PK
13	215-0001-SP	KIT, SPRING, STEM, 25/PK
14	208-5007-SP	KIT, O-RING, 2-007, EPDM, 100/PK
15	645-0065-SP	KIT, PLATE ASSY, PLUNGER, RETAINER, 6B, BLACK, 5/PK
	645-0011-SP	KIT, PLATE ASSY, PLUNGER, RETAINER, 10B, BLACK, 5/PK
	645-0068-SP	KIT, PLATE ASSY, PLUNGER, RETAINER, 12B, BLACK, 5/PK
	645-0071-SP	KIT, PLATE ASSY, PLUNGER, RETAINER, 14B, BLACK, 5/PK
16	220-0001-SP	KIT, SCREW, 6-32 x .375, 100 DEG FHP, 100/PK
17	808-0018-SP	KIT, LABEL, PLATE, BOTTOM, 50/PK
18	208-5003-SP	KIT, O-RING, 2-003, EPDM, 100/PK
19	625-0001-SP	KIT, SCREW ASSY, WATER, BRIX, 25/PK
20	265-0194-SP	KIT, BODY, NOZZLE, BLACK, 5/PK
21	210-0006-SP	KIT, SEAL, HANDLE, 5/PK
22	808-0388-SP	KIT, LABEL, DOMED, BG, RATTLER, 8/SHEET
23	808-0278-SP	KIT, LABEL, TWIST-ON, BARGUN, 25/PK
24	265-0001-SP	KIT, RETAINER, BUTTERFLY, 100/PK

MANIFOLD ASSEMBLY

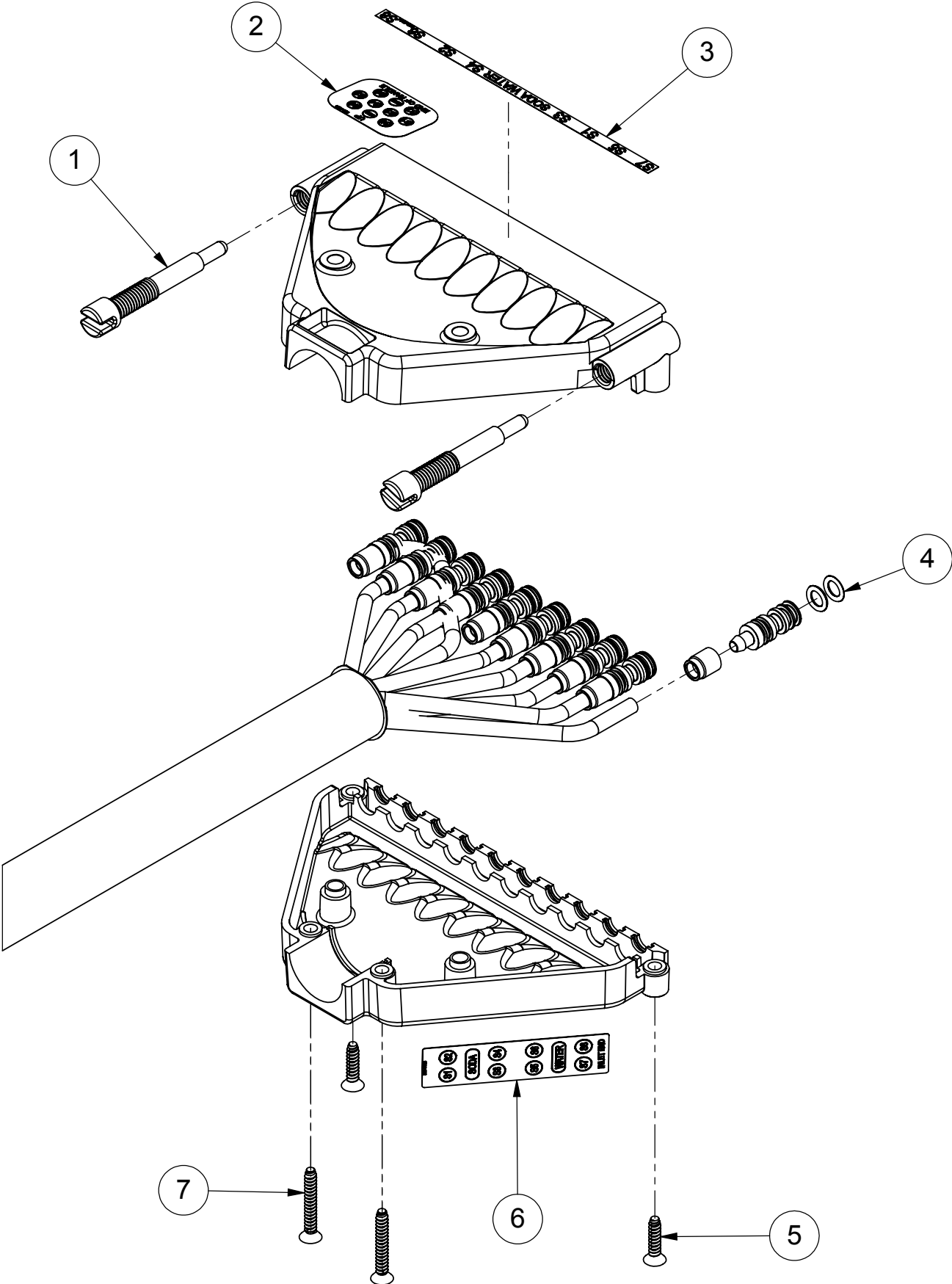

MANIFOLD ASSEMBLY

BARGUN MANIFOLD PARTS LIST		
ITEM	SCHROEDER PN	DESCRIPTION
1	265-0076-SP	KIT, SCREW, SEPARATOR, 10/PK
2	808-0054-SP	KIT, LABEL, HANDLE LAYOUT, 10B, 5/PK
	808-0061-SP	KIT, LABEL, HANDLE LAYOUT, 12B, 5/PK
	808-0071-SP	KIT, LABEL, HANDLE LAYOUT, 14B, 5/PK
3	808-0361-SP	KIT, LABEL, HOUSING LAYOUT, 10B, COMPACT BG, 4/PK
	808-0384-SP	KIT, LABEL, HOUSING LAYOUT, 14B, COMPACT BG, 4/PK
4	208-5010-SP	KIT, O-RING, 2-010, EPDM, 100/PK
5	224-0019-SP	KIT, SCREW, 8-16 x .688, PH, FHD, PLS, SS, 100/PK
6	808-0055-SP	KIT, LABEL, BUTTON LAYOUT, 10B, 5/PK
	808-0063-SP	KIT, LABEL, BUTTON LAYOUT, 12B, 5/PK
	808-0064-SP	KIT, LABEL, BUTTON LAYOUT, 14B, 5/PK
7	224-0018-SP	KIT, SCREW, 8-16 x 1.125, PH, FHD, PLS, SS, 100/PK

FLOW CONTROL MODULE ASSEMBLY

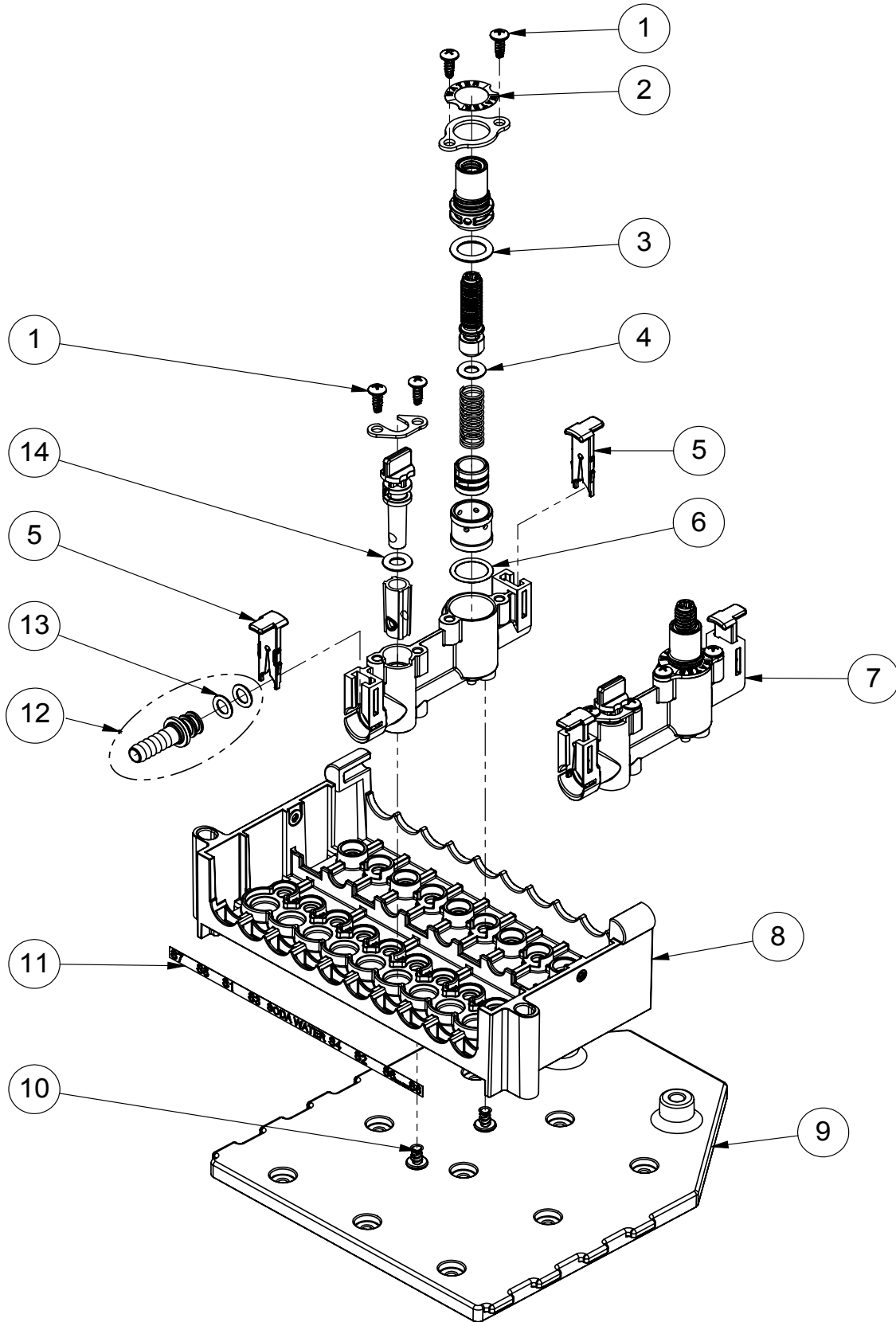

FLOW CONTROL MODULE ASSEMBLY

BARGUN FLOW CONTROL MODULE PARTS LIST		
ITEM	SCHROEDER PN	DESCRIPTION
1	224-0005-SP	KIT, SCREW, 6-19 x .375, PLASTITE, PH, PHD, 100/PK
2	808-0363-SP	KIT, LABEL, SODA, VALVE, COMPACT BG, 16/SHEET
	808-0364-SP	KIT, LABEL, WATER, VALVE, COMPACT BG, 16/SHEET
	808-0365-SP	KIT, LABEL, S1, VALVE, COMPACT BG, 16/SHEET
	808-0366-SP	KIT, LABEL, S2, VALVE, COMPACT BG, 16/SHEET
	808-0367-SP	KIT, LABEL, S3, VALVE, COMPACT BG, 16/SHEET
	808-0368-SP	KIT, LABEL, S4, VALVE, COMPACT BG, 16/SHEET
	808-0369-SP	KIT, LABEL, S5, VALVE, COMPACT BG, 16/SHEET
	808-0370-SP	KIT, LABEL, S6, VALVE, COMPACT BG, 16/SHEET
	808-0371-SP	KIT, LABEL, S7, VALVE, COMPACT BG, 16/SHEET
	808-0372-SP	KIT, LABEL, S8, VALVE, COMPACT BG, 16/SHEET
	808-0373-SP	KIT, LABEL, S9, VALVE, COMPACT BG, 16/SHEET
	808-0374-SP	KIT, LABEL, S10, VALVE, COMPACT BG, 16/SHEET
	808-0375-SP	KIT, LABEL, S11, VALVE, COMPACT BG, 16/SHEET
808-0376-SP	KIT, LABEL, S12, VALVE, COMPACT BG, 16/SHEET	
3	208-5111-SP	KIT, O-RING, 2-111, EPDM, 100/PK
4	208-5107-SP	KIT, O-RING, 2-107, EPDM, 100/PK
5	265-0759-SP	KIT, RETAINER, COMPACT, CLIP, 1/4" FITTING, 50/PK
6	208-5014-SP	KIT, O-RING, 2-014, EPDM, 100/PK
7	639-0060-SP	VALVE ASSY, FC, LONG-OUTLET, SYRUP, COMPACT BG
	639-0061-SP	VALVE ASSY, FC, SHORT-OUTLET, SYRUP, COMPACT BG
	639-0062-SP	VALVE ASSY, FC, SODA, COMPACT BG
	639-0063-SP	VALVE ASSY, FC, WATER, COMPACT BG
	639-0064-SP	VALVE ASSY, FC, LONG-OUT, DIET, COMPACT BG
8	265-0771	HOUSING, VALVES, 10B, COMPACT BG
	265-0772	HOUSING, VALVES, 12/14B, COMPACT BG
9	265-0762	PLATE, MOUNTING, 10B, W/INSERTS, COMPACT BG
	265-0766	PLATE, MOUNTING, 12/14B, W/INSERTS, COMPACT BG
10	224-0020-SP	KIT, SCREW, 8-16 x .250, PLASTITE, PH, PHD, 100/PK
11	808-0361-SP	KIT, LABEL, HOUSING LAYOUT, 10B, COMPACT BG, 4/PK
	808-0384-SP	KIT, LABEL, HOUSING LAYOUT, 14B, COMPACT BG, 4/PK
12	625-0067-SP	KIT, FITTING ASSY, 1/4 BARB x 1.25"L, W/FLANGE, 25/PK
13	208-5010-SP	KIT, O-RING, 2-010, EPDM, 100/PK
14	208-5108-SP	KIT, O-RING, 2-108, EPDM, 100/PK

MECHANICAL MODULE ASSEMBLY

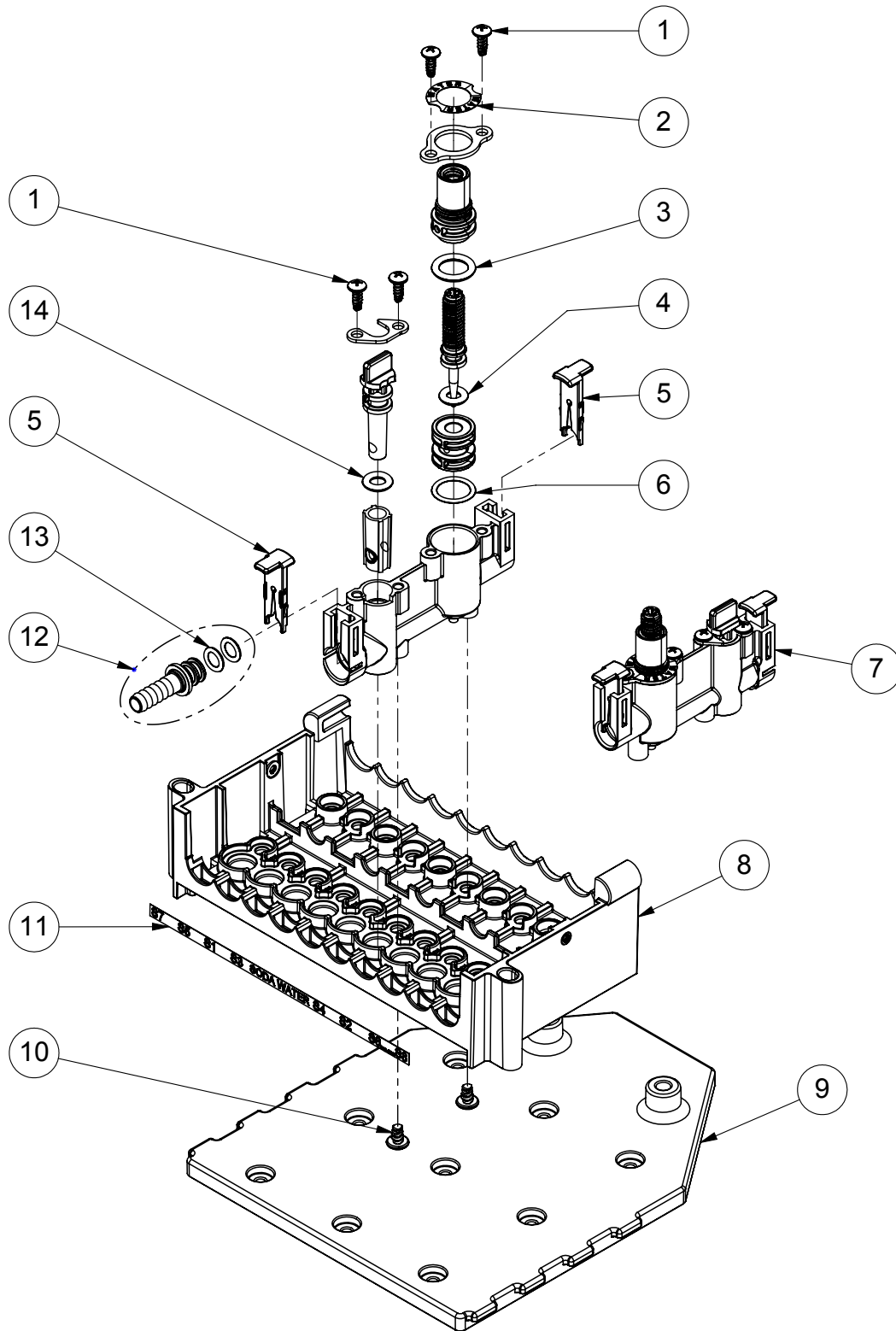

MECHANICAL MODULE ASSEMBLY

BARGUN MECHANICAL MODULE PARTS LIST		
ITEM	SCHROEDER PN	DESCRIPTION
1	224-0005-SP	KIT, SCREW, 6-19 x .375, PLASTITE, PH, PHD, 100/PK
2	808-0363-SP	KIT, LABEL, SODA, VALVE, COMPACT BG, 16/SHEET
	808-0364-SP	KIT, LABEL, WATER, VALVE, COMPACT BG, 16/SHEET
	808-0365-SP	KIT, LABEL, S1, VALVE, COMPACT BG, 16/SHEET
	808-0366-SP	KIT, LABEL, S2, VALVE, COMPACT BG, 16/SHEET
	808-0367-SP	KIT, LABEL, S3, VALVE, COMPACT BG, 16/SHEET
	808-0368-SP	KIT, LABEL, S4, VALVE, COMPACT BG, 16/SHEET
	808-0369-SP	KIT, LABEL, S5, VALVE, COMPACT BG, 16/SHEET
	808-0370-SP	KIT, LABEL, S6, VALVE, COMPACT BG, 16/SHEET
	808-0371-SP	KIT, LABEL, S7, VALVE, COMPACT BG, 16/SHEET
	808-0372-SP	KIT, LABEL, S8, VALVE, COMPACT BG, 16/SHEET
	808-0373-SP	KIT, LABEL, S9, VALVE, COMPACT BG, 16/SHEET
	808-0374-SP	KIT, LABEL, S10, VALVE, COMPACT BG, 16/SHEET
	808-0375-SP	KIT, LABEL, S11, VALVE, COMPACT BG, 16/SHEET
	808-0376-SP	KIT, LABEL, S12, VALVE, COMPACT BG, 16/SHEET
3	208-5111-SP	KIT, O-RING, 2-111, EPDM, 100/PK
4	208-5107-SP	KIT, O-RING, 2-107, EPDM, 100/PK
5	265-0759-SP	KIT, RETAINER, COMPACT, CLIP, 1/4" FITTING, 50/PK
6	208-5014-SP	KIT, O-RING, 2-014, EPDM, 100/PK
7	639-0065-SP	VALVE ASSY, MC, LONG-OUTLET, COMPACT BG
	639-0066-SP	VALVE ASSY, MC, SHORT-OUTLET, COMPACT BG
	639-0068-SP	VALVE ASSY, MECHANICAL, WATER, COMPACT BG
	639-0069-SP	VALVE ASSY, MECHANICAL, SODA, COMPACT BG
8	265-0771	HOUSING, VALVES, 10B, COMPACT BG
	265-0772	HOUSING, VALVES, 12/14B, COMPACT BG
9	265-0762	PLATE, MOUNTING, 10B, W/INSERTS, COMPACT BG
	265-0766	PLATE, MOUNTING, 12/14B, W/INSERTS, COMPACT BG
10	224-0020-SP	KIT, SCREW, 8-16 x .250, PLASTITE, PH, PHD, 100/PK
11	808-0361-SP	KIT, LABEL, HOUSING LAYOUT, 10B, COMPACT BG, 4/PK
	808-0384-SP	KIT, LABEL, HOUSING LAYOUT, 14B, COMPACT BG, 4/PK
12	625-0067-SP	KIT, FITTING ASSY, 1/4 BARB x 1.25"L, W/FLANGE, 25/PK
13	208-5010-SP	KIT, O-RING, 2-010, EPDM, 100/PK
14	208-5108-SP	KIT, O-RING, 2-108, EPDM, 100/PK

MOUNTING PLATE SCREW PLACEMENT

10 BUTTON
MOUNTING PLATE
5 MOUNTING SCREWS

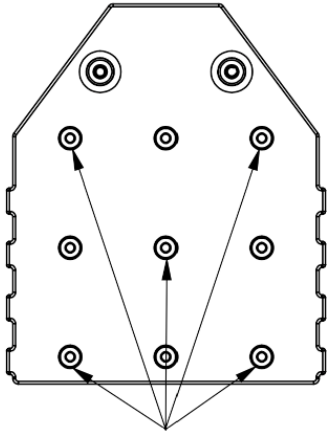

USE THESE MOUNTING HOLES
FOR BEST STABILITY

12/14 BUTTON
MOUNTING PLATE
6 MOUNTING SCREWS

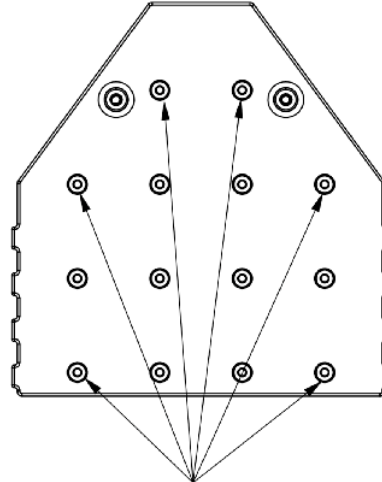

USE THESE MOUNTING HOLES
FOR BEST STABILITY

PATENT PENDING

PATENT & PATENT PENDING NUMBERS

UNITED STATES

7,658,006 8,109,413
8,123,079 8,336,736
8,387,829 8,418,888
8,479,954 8,770,442
8,807,395 8,814,003
9,840,406 D697,753
D717,590 D717,591
D717,592 D717,593
D786,616 D758,795

UNITED KINGDOM

GB2468792 GB2474741
GB2476347 GB2480531
GB2480532

AUSTRALIA

346264, 346389,
AU201912368S

MEXICO

41390, 317084, 31399

EUROPE

2300353, 2336076,
002159194, RCD NO.
006408092-0001

NEW BAR GUN PART NUMBER FORMAT

Bar Gun part numbers are formatted to capture all relevant information about a product so that it can be tracked manufacturing, sale, troubleshooting and warranty purposes. As of 01/01/19, the format for the Bar Gun part number will be as follows:

The legacy part number will still be referenced in your order confirmation, packing lists, and invoices.

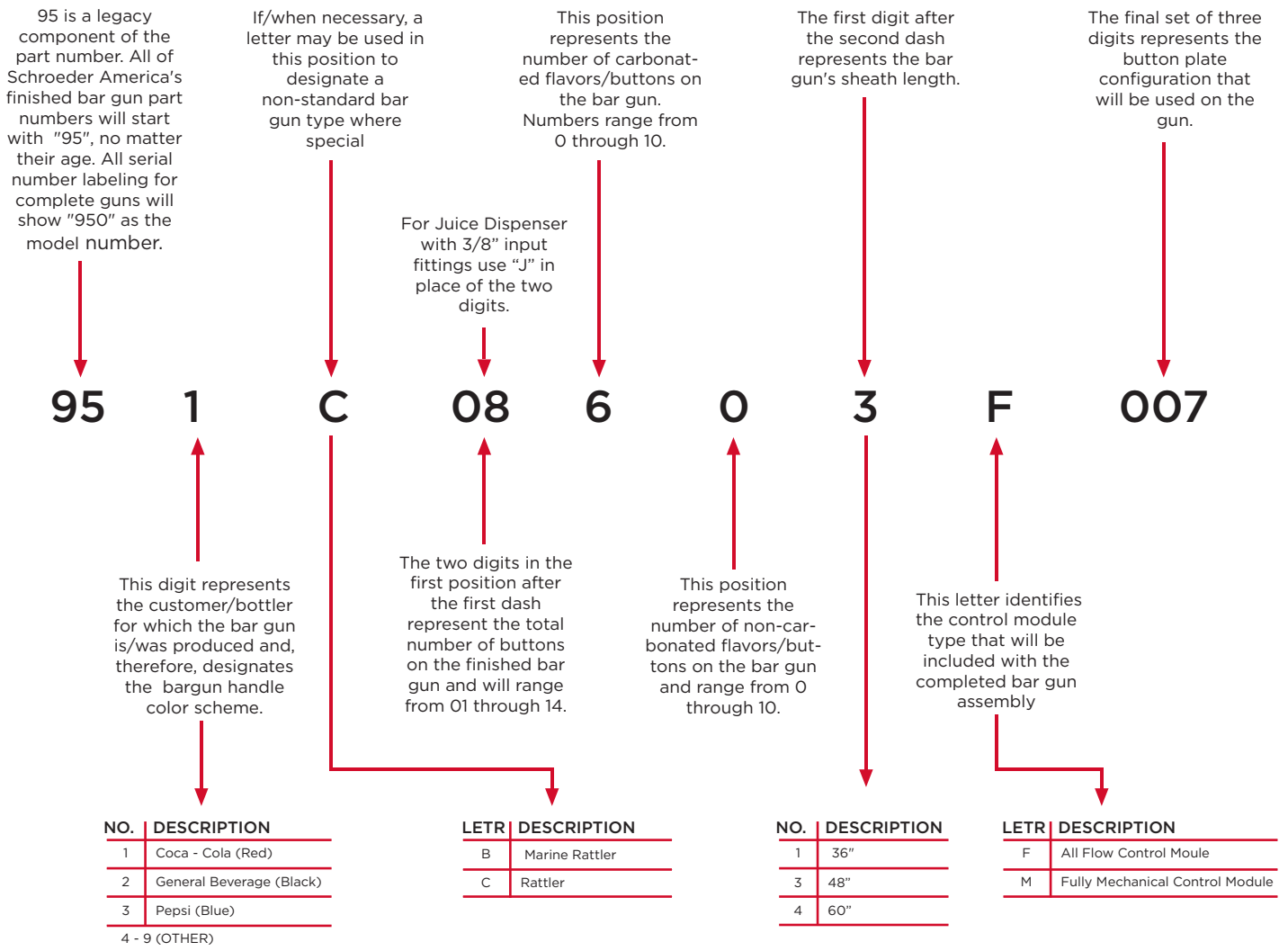

952C - 0860 - 3F007 represents a General Beverage, Rattler Bar Dispenser with 8 Buttons. 6 buttons are for carbonated flavors and 0 buttons are for non-carbonated flavors. The unit has a 48" sheath and an all flow control module assembly. It uses button plate configuration 007. (Old PN 950-08600-1-01-48-007)